

ATLAS

Krane / Cranes / Grues



TC13C

SF2

SF3

MAX. HUBMOMENT LIFTING MOMENT COUPLE DE LEVAGE	12 kNm (1.1 m) 8680 ft.lbs	12 kNm (1.1 m) 8680 ft.lbs
MAX. HUBKRAFT MAX. LIFTING CAPACITY PUISSANCE DE LEVAGE	990 kg 2182 lbs	990 kg 2182 lbs
MAX. HYDRAULISCHE REICHWEITE MAX. HYDRAULIC OUTREACH PORTÉE HYDRAULIQUE MAXIMALE	2.66 m 8.72 ft	3.46 m 11.35 ft
SCHWENKBEREICH SLEWING ANGLE ANGLE DE ROTATION	340°	340°
SCHWENKMOMENT SLEWING TORQUE COUPLE DE ROTATION	3.2 kNm (0.33 m) 2390 ft.lbs	3.2 kNm (0.33 m) 2390 ft.lbs
MAX. BETRIEBSDRUCK OPERATING PRESSURE PRESSION D'UTILISATION	19.0 Mpa (190 bar) 2755 psi	19.0 Mpa (190 bar) 2755 psi
EMPFOHLENE FORDERMENGE DER PUMPE RECOMMENDED PUMP CAPACITY DÉBIT DE POMPE RECOMMANDÉ	6 l/min 1.3 imp. gal/min 1.6 US gal/min	6 l/min 1.3 imp. gal/min 1.6 US gal/min

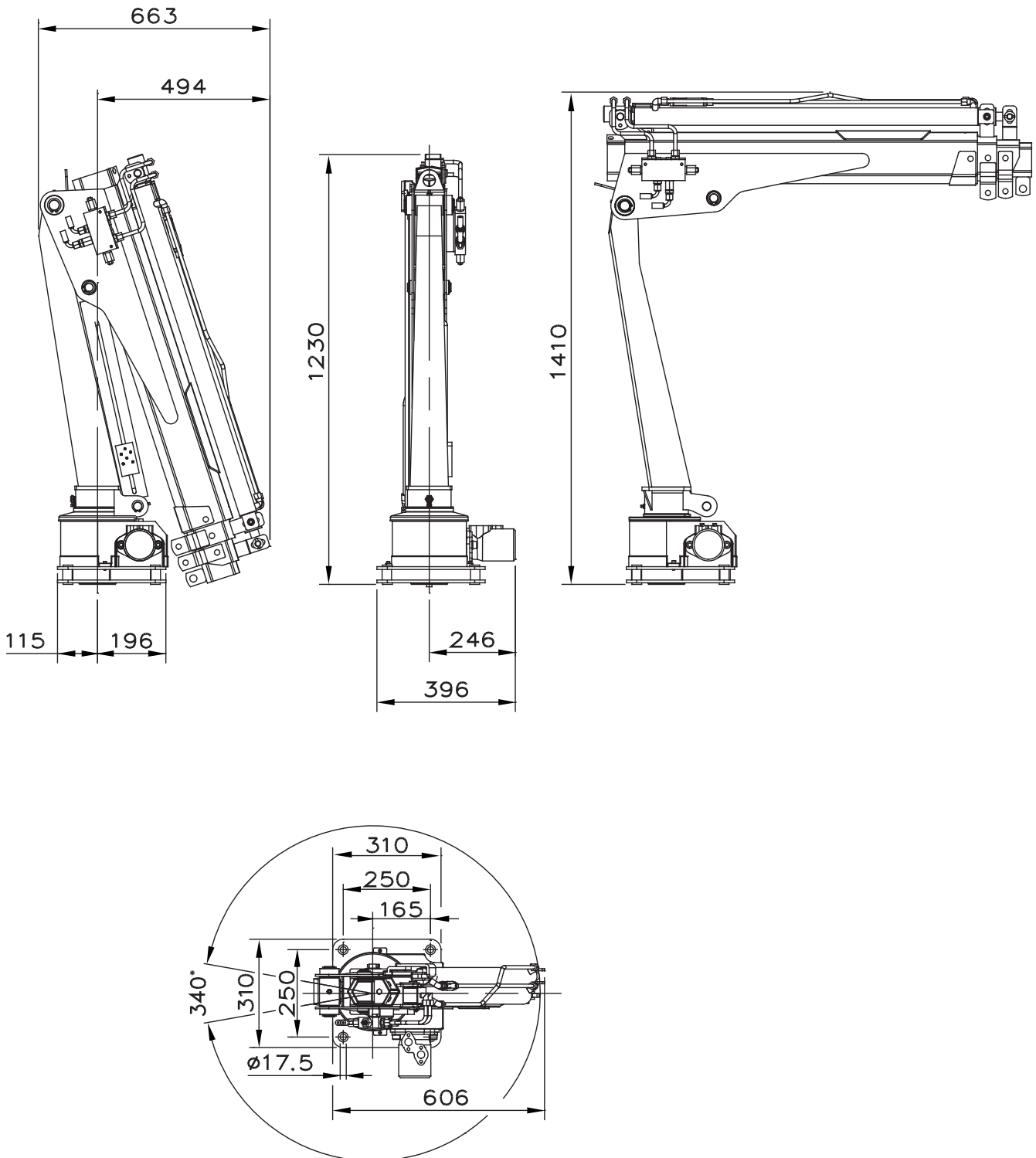

TC13C – SF2

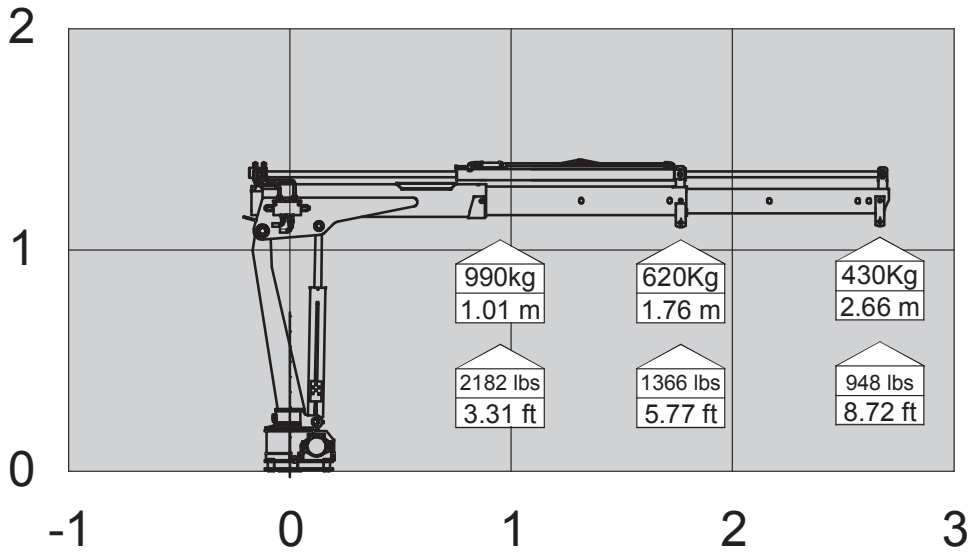

TC13C – SF3

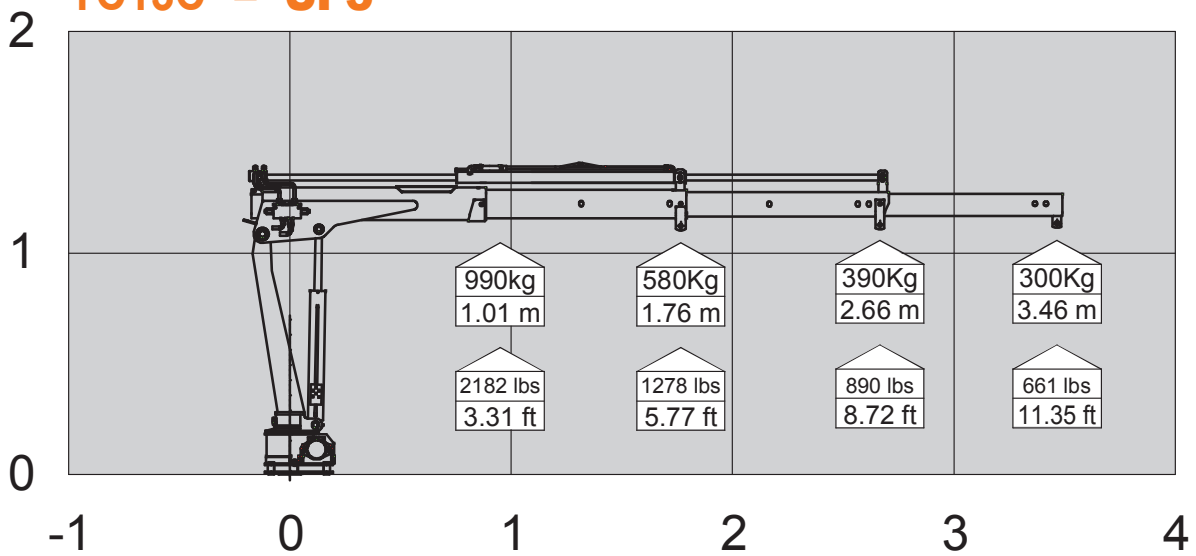

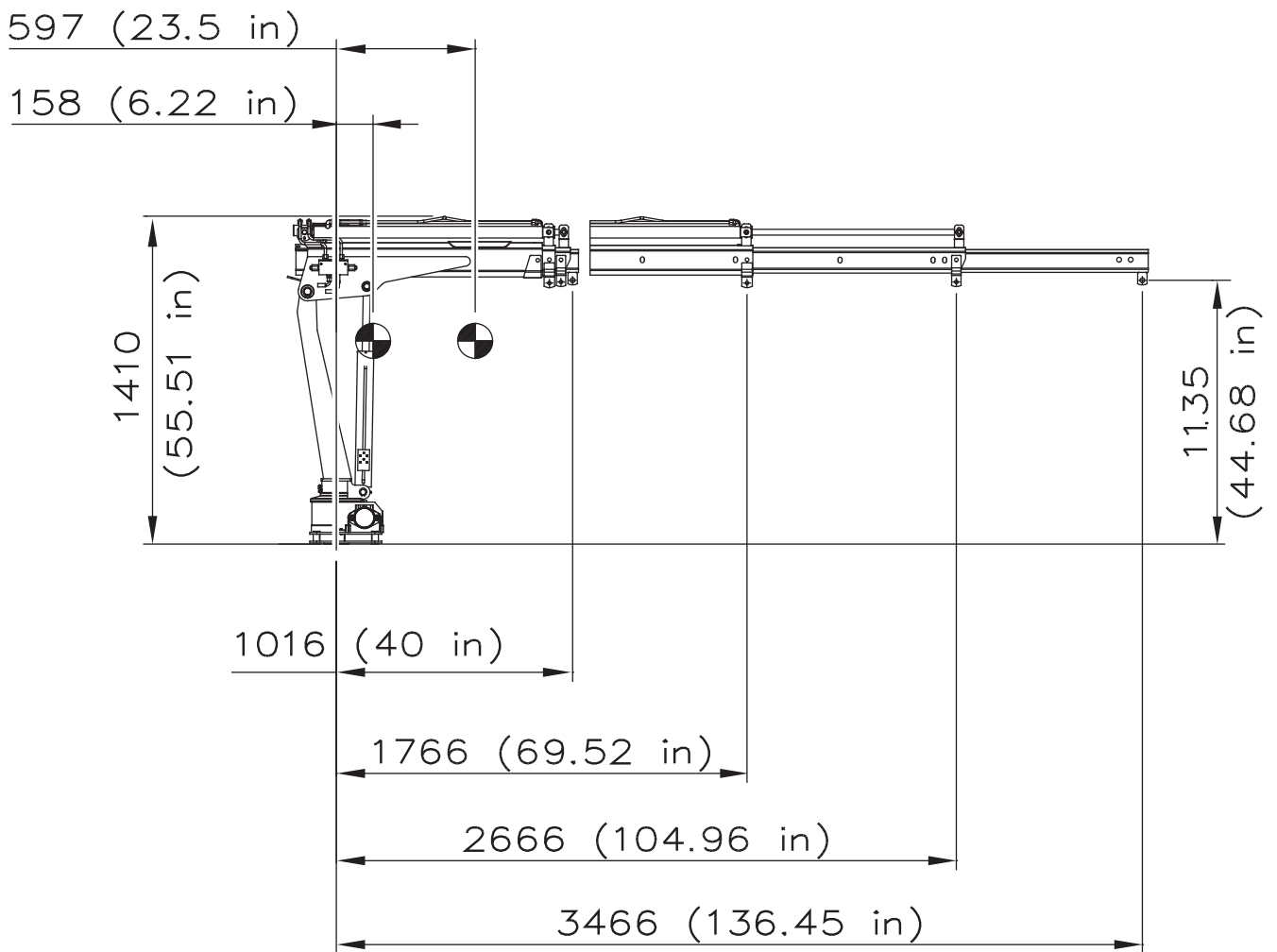

	Gewicht	Weight	Poids
SF2		165 kg	
SF3		187 kg	

TC13C

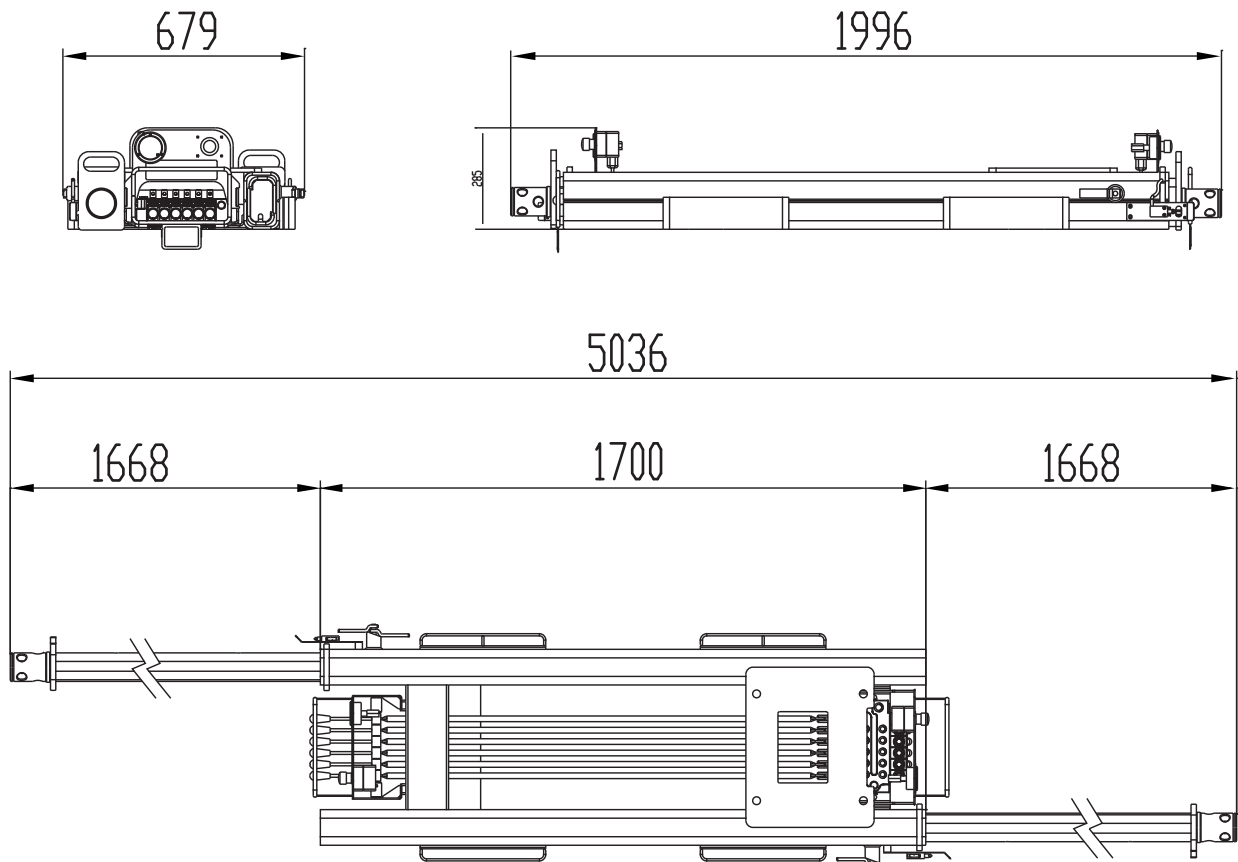

OPTIONAL

BASISVERSION "CE"
BASE "CE" VERSION
VERSION DE BASE "CE"

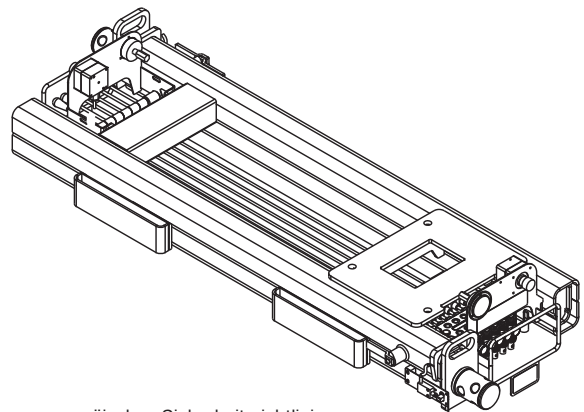

Konstruktionsänderungen vorbehalten, Angaben unverbindlich, Geräte sind konform mit neuen europäischen Sicherheitsrichtlinien.

Design modifications reserved, specifications non-binding, units are in conformance with new European safety guidelines.

Sous réserve de modifications de la construction, indications sans engagement, les engins sont conformes aux nouvelles directives européennes en matière de sécurité.

ATLAS

Atlas Maschinen GmbH
Stedinger Straße 324 · D-27751 Delmenhorst
Tel. +49 (0) 4221-491-0 · Fax +49 (0) 4221-491-443
info@atlasgmbh.com · www.atlasgmbh.com

Händler: